



## RAPTOR EcoKap Stapling System

In one easy step, the RC-SH/04 Eco pneumatic cap stapler drives RAPTOR® 16 gauge, SH/04, composite staples through the patented paper cap to hold thin layers of fabric, paper, plastic wrap or woven wrap.

This system provides excellent strain relief so the staple will not rip through in windy conditions. It is an extremely fast, comfortable, lightweight, maneuverable, well-balanced, sturdy and durable tool, built for production applications.

The open design makes staple and cap reloading easy. The high capacity canister holds 300 caps per reel and the stapler magazine holds 70 staples. The switchable trigger creates an easy transition to bump fire from sequential fire. Additionally, this tool can easily switch between stapling caps to driving staples only.



### TECHNICAL DATA

Tool Model	RC-SH/04 Eco
Canister capacity / Magazine capacity	300 caps / 70 staples
Operating air pressure	70 – 110 psi (4.8 – 7.6 bar)
Dimensions LxWxH	15.5" x 4" x 10.5" (394 x 102 x 267mm)
Weight	4.8 lb (2.2 kg)
Safety	Contact & Sequential drive



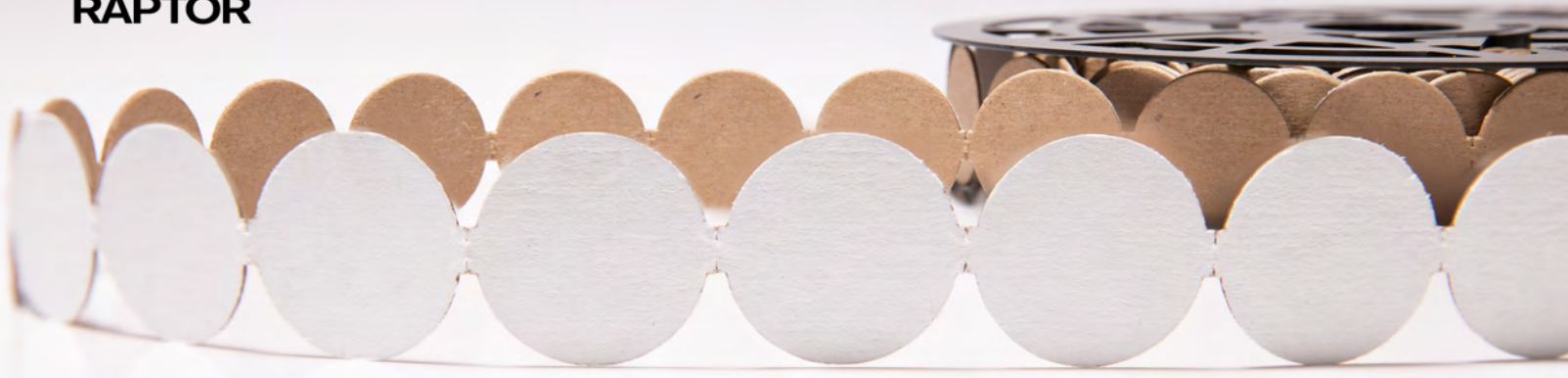

## RC-EcoKaps

- **Pulpable** - The EcoKap is made from 100% recycled paperboard that is Forestry Stewardship Council certified. This paperboard material is designed to be combined with other lumber mill byproducts without lowering the grade and so will not interfere with pulp processing.
- **EcoFriendly** - With strong, long lasting holding power these biodegradable caps will keep your wrap securely fastened and keep you free from worrying about leaving plastic in the environment once the caps are removed.
- **Safer than traditional methods** - Traditional methods using square paper tabs make it easy to staple your hand or other extremities. Our all-in-one system keeps your hands at a safe distance from the nose of the tool.



### ButtonKap® Recycled Paperboard Caps

Item number: RC-EcoKap

Diameter: 1" (25.4mm)

Caps per coil: 300

Caps per box: 18,000

Coils per box: 60

US Patent 10,358,825



# Fastener Type

## RAPTOR® SH/04

### 16 Gauge Composite Staple

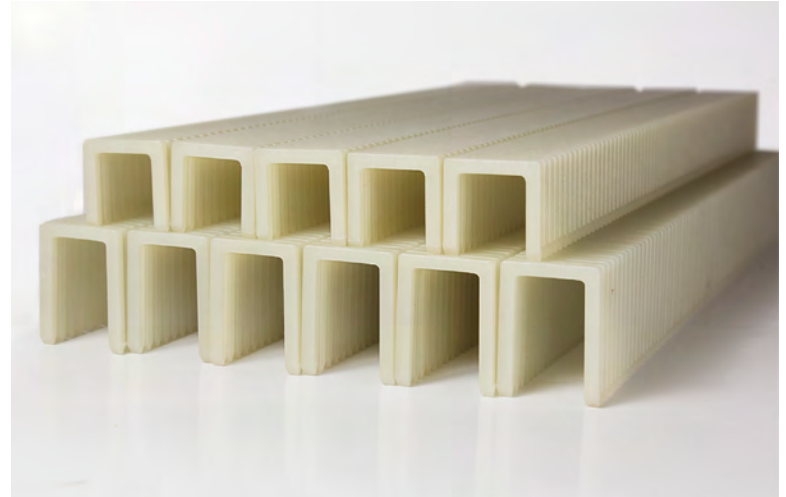
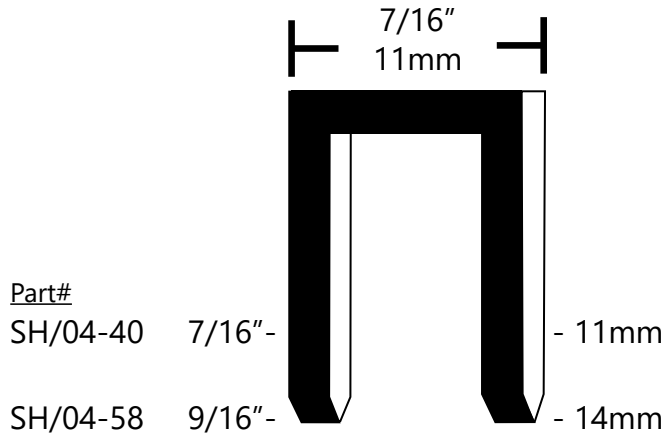

Packaging: 5040 staples per box • 20 boxes per case

#### BENEFITS

- ✓ **Sawable, Sandable & Planeable**
- ✓ **Never Rusts or Corrodes**
- ✓ **Bonds Like Glue**
- ✓ **Completely Non-Metal**

#### APPLICATIONS

Lumber wrap  
 Lumber tagging  
 Boatbuilding  
 Fiberglass lay up  
 Composites manufacturing  
 Radiant barrier installation  
 Wire installation  
 House wrap  
 Casket lining  
 Casegoods tagging

#### TOOLS

Pneumatic:  
 RC-SH/04 Cap Stapler  
 RC-SH/04 EcoKap Stapler  
 OMER 83P Series

Manual:  
 RAPTOR® G-3PS  
 Hammer Tacker (*max 7/16"*)  
 RAPTOR® CT-H7000P  
 Compression Tacker

#### Material Grades:

**Standard Material:** Provides the best drivability. It is not recommended for high speed steel moulder knives but it is fine for carbide blades. In one particular customer test, Titan V24RW, BB knives were used with our standard RAPTOR® product fastened in a line and the knives showed no signs of damage.

**LF Material:** Safe for most moulder blades but drivability is somewhat compromised.

**NF Material:** Safe for all delicate blades but drivability is somewhat compromised.

**Colors:** RAPTOR® fasteners are available in colors such as White, Brown, Redwood, Cedar, Blue, Red and Gray. Please contact us for minimum order requirements and lead times.

